



Steca Solarix PRS

PRS 1010, PRS 1515, PRS 2020, PRS 3030

The simplicity and high performance of the Steca Solarix PRS solar charge controller make it particularly appealing. At the same time, it offers a modern design and a convenient display, all at an extremely attractive price.

Several LEDs in various colours emulate a tank display, which gives information on the battery's state of charge. Here, Steca's latest algorithms are employed, resulting in optimal battery maintenance. The Solarix PRS charge controllers are equipped with an electronic fuse, thus making optimal protection possible. They operate on the serial principle, and separate the solar module from the battery in order to protect it against overcharging.

For larger projects, the charge controllers can also be equipped with special functions: e.g. with night light function and selectable charging plateau and deep-discharge protection voltages.

Product features

- Series controller
- Automatic detection of voltage
- Voltage and current regulation
- PWM control
- Multistage charging technology
- Current compensated load disconnection
- Automatic load reconnection
- Temperature compensation
- Common positive grounding or negative grounding on one terminal
- Integrated self test
- Monthly maintenance charge

Electronic protection functions

- Overcharge protection
- Deep discharge protection
- Reverse polarity protection of load, module and battery
- Automatic electronic fuse
- Short circuit protection of load and module
- Overvoltage protection at module input
- Open circuit protection without battery
- Reverse current protection at night
- Overtemperature and overload protection
- Battery overvoltage shutdown

Displays

- Multifunction LED display
- Multi-coloured LED
- 5 LEDs show operating states
 - for operation, state of charge, fault messages

Options

- Night light function pre-set in the factory or adjustable via Steca PA RC 100
- Parameterisation of function values via Steca PA RC 100

Certificates

- Compliant with European Standards (CE)
- RoHS compliant
- Made in Germany
- Developed in Germany
- Manufactured according to ISO 9001 and ISO 14001

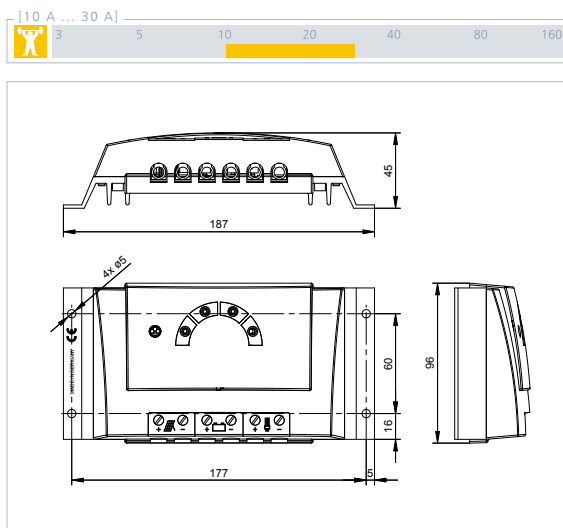

	PRS 1010	PRS 1515	PRS 2020	PRS 3030
Characterisation of the operating performance				
System voltage	12 V (24 V)			
Own consumption	< 4 mA			
DC input side				
Open circuit voltage solar module	< 47 V			
Module current	10 A	15 A	20 A	30 A
DC output side				
Battery voltage	9 V ... 17 V (17.1 V ... 34 V)			
Load current	10 A	15 A	20 A	30 A
End of charge voltage	13.9 V (27.8 V)			
Boost charge voltage	14.4 V (28.8 V)			
Equalisation charge	14.7 V (29.4 V)			
Reconnection voltage (LVR)	12.4 V ... 12.7 V (24.8 V ... 25.4 V)			
Deep discharge protection (LVD)	11.2 V ... 11.6 V (22.4 V ... 23.2 V)			
Operating conditions				
Ambient temperature	-25 °C ... +50 °C			
Fitting and construction				
Terminal (fine / single wire)	16 mm ² / 25 mm ² - AWG 6 / 4			
Degree of protection	IP 32			
Dimensions (X x Y x Z)	187 x 96 x 45 mm			
Weight	345 g			

Technical data at 25 °C / 77 °F



Steca PA RC100 Remote control

[areas of application]



720W